

INSTALLATION & OWNER MANUAL

AMBIUS

LED MIRROR LIGHT 900MM

Model: AMIR15W900 - Q5030110

PRODUCT & TECHNICAL INFORMATION

Wattage: 15W Integrated LEDs (Non replaceable)

Lumens: 1200-1400 Lumens

Colour Temperature: 3000K 4000K 5700K

Ingress Protection: IP54

CRI: >80

Material: Aluminium

Beam Angle: Up: 110°

Down: 110° x 5° Asymmetric

Supply: 220-240V ~ 50/60Hz

Estimated Life: 50,000 Hours+

Use: Indoor Bathroom Zone 3 (Permanent use)



SAFETY WARNINGS

- Always read the instructions carefully before installation, failure to do this could result in damage to the product, property or harm to the installer.
- **This product must be installed by a licensed electrician in accordance with the Australian / New Zealand Wiring Rules AS/NZS 3000.**
- Allow suitable ventilation around the light fitting and do not cover with any material.
- Do not immerse any part of the light fitting in water or any other liquids.
- Regularly inspect the light fitting to ensure that no damage has occurred, if damage is found cease use and replace. Do not attempt to modify this fitting in any way.
- The light source of this luminaire is not replaceable; when the light source reaches its end of life the whole luminaire shall be replaced.

DIMENSIONS

Units:mm

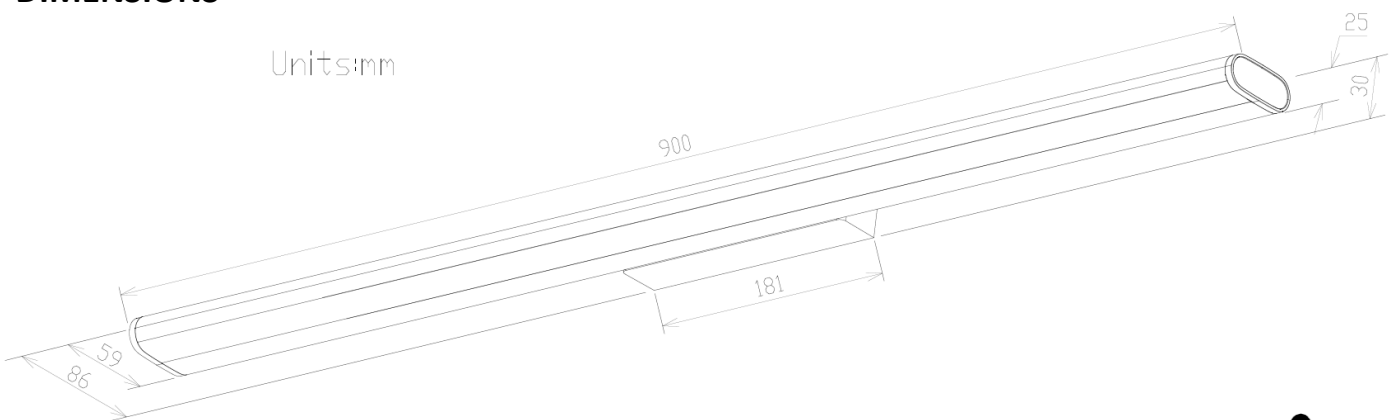

PLEASE READ AND UNDERSTAND ALL WARNINGS, CAUTIONS AND OPERATING INSTRUCTIONS IN THIS MANUAL BEFORE USING THIS EQUIPMENT. Failure to follow all instructions may result in electric shock, fire and/or serious personal injury.

INSTALLATION

CAUTION: ISOLATE (TURN OFF) MAINS SUPPLY BEFORE CONNECTING THE LIGHT.

Ensure all packaging materials are fully removed prior to installation.

ACCESSORIES

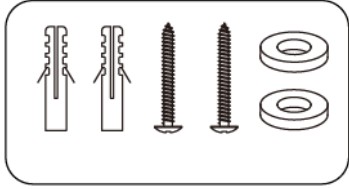

2 x Rawl Plugs

2 x Screws

2 x Washers

1. Remove the screw from the top of the light fixture as shown below.

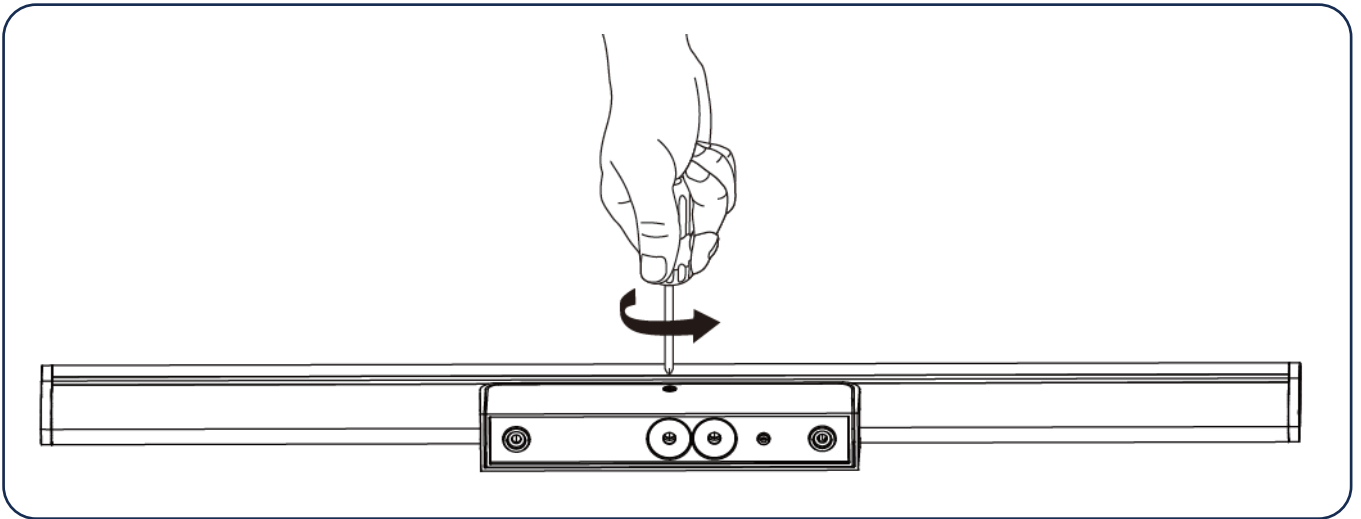

2. Remove base by sliding towards you Fig.1.

3. Select your preferred colour temperature Fig.2: WW-3000K, NW-4000K or CW-5700K.

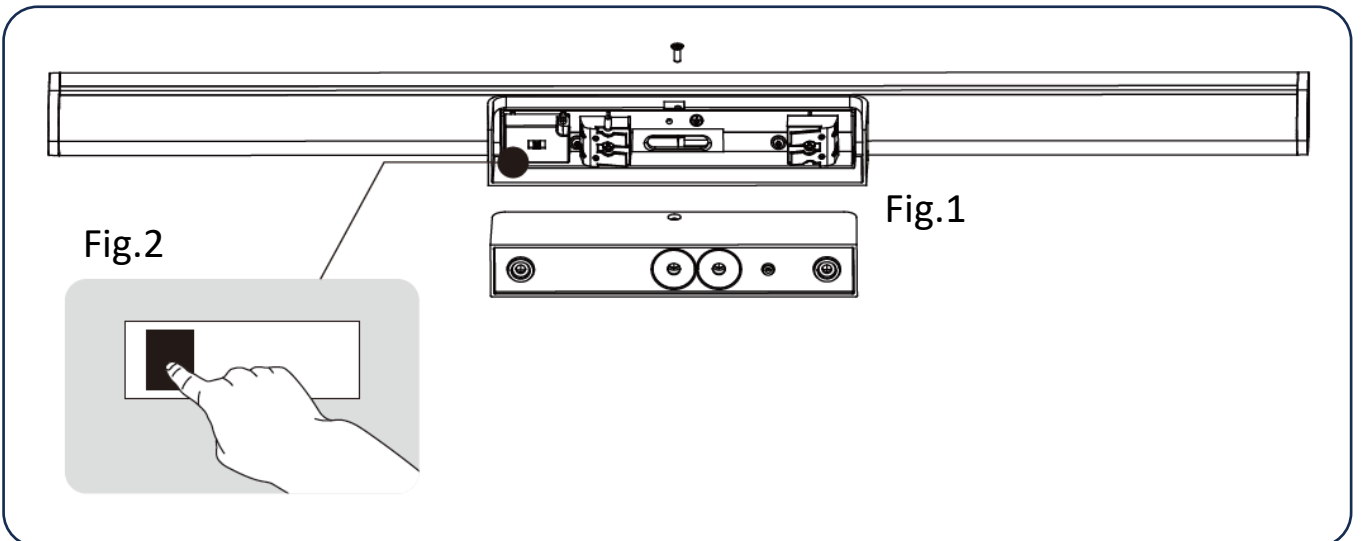

INSTALLATION Cont.

4. Select the appropriate mounting position.
5. Route the supply cable so that the wiring is able to be connected to the terminal block through the back of the mounting plate / base.
6. Mark your mounting position using the base plate before drilling holes.
7. Attach the mounting bracket using the screws provided as per below Fig.3.

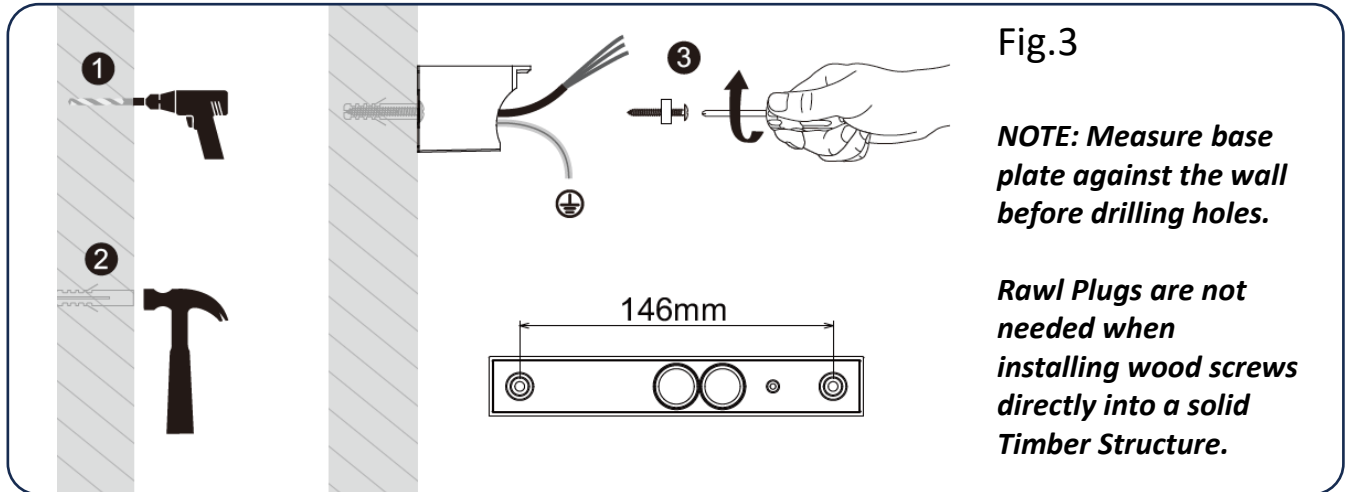

8. Connect the power cable from the mains to the terminals:
 - a) Brown (Active/Live) is connected to the contact marked 'A' or 'L'.
 - b) Blue (Neutral) is connected to the contact marked 'N'.
 - c) Green/Yellow (Earth) is connected to the contact marked .
9. Ensure that any connection made complies with New Zealand Electrical Wiring rules AS/NZS 3000. Connections should be secure.
10. Attach the lighting fixture to the base plate
11. Energise the circuit at the mains then turn the individual switch 'ON'.
12. Your light fitting should now operate.

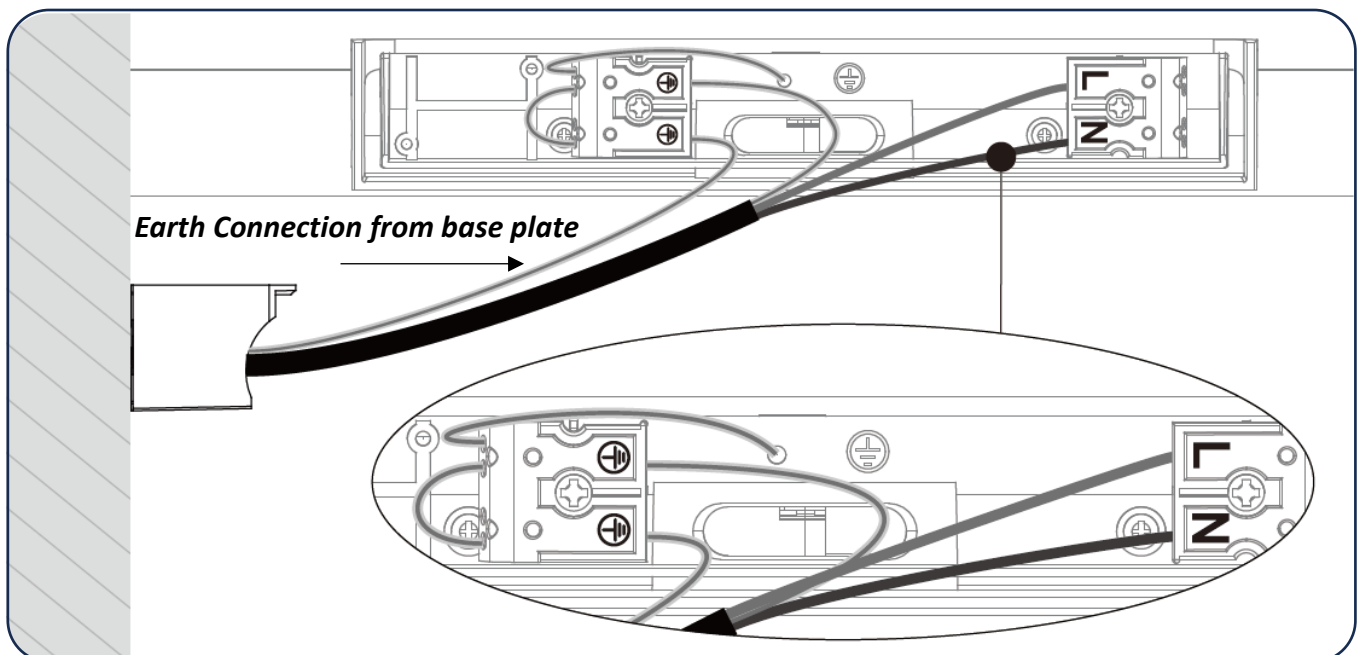

CARE AND CLEANING

To clean wipe exterior with a damp cloth
Do not immerse in water.

DISPOSAL

When this fixture is no longer used or required it should be disposed of with household waste. We recommend completing this in the most environmentally friendly way. Please recycle where facilities exist in your local area. Check with your council authority for recycling advice. Recycling of packaging materials reduces the need for landfill. Please recycle packaging where possible. Check with your local council authority for recycling advice.

PROOF OF PURCHASE

Please retain your purchase receipt for all warranty claims

WARRANTY

Your product is warranted against faults and manufacture when used in normal domestic use for a period of three years.

We undertake to replace this product at no charge if found to be defective due to a manufacturing fault during the warranty period. This warranty excludes damage caused by misuse, neglect, shipping accident, incorrect installation, or work carried out by anyone other than a qualified electrical service technician.

If your product fails to operate satisfactorily, please return it to the retailer from whom it was purchased to obtain a replacement product. You will need to produce satisfactory evidence of date of purchase. If the product is to be replaced (cannot be repaired) then that replacement will be of the same or similar product or accessory excluding packaging, instruction card etc.

In New Zealand product is covered by the Consumers Guarantee Act (1993). In accordance with the act consumers are advised that: The manufacturer does not undertake that repair facilities and parts are necessarily available for this product.

In Australia, our goods come with guarantees that cannot be excluded under the Australian Consumer Law. You are entitled to a replacement or refund for a major failure and compensation for any other reasonably foreseeable loss or damage. You are also entitled to have the goods repaired or replaced if the goods fail to be of acceptable quality and the failure does not amount to a major failure.

KEEP IN A SAFE PLACE FOR FUTURE REFERENCE

CDB  GROUP

New Zealand

PO Box 100-707
N.S.M.C
Auckland

Phone +64 (0)9 917 4000
Phone 0800 232 633
info@cdb.co.nz

Australia

PO Box 574
South Morang
Victoria, 3752

Phone +61 (0)3 9336 4423
Phone 1300 465 324
info@cdbgoldair.com.au